

版本 REV.	日期 DATE	ECN NO.	变更内容 DESCRIPTION	制图 DRAWN

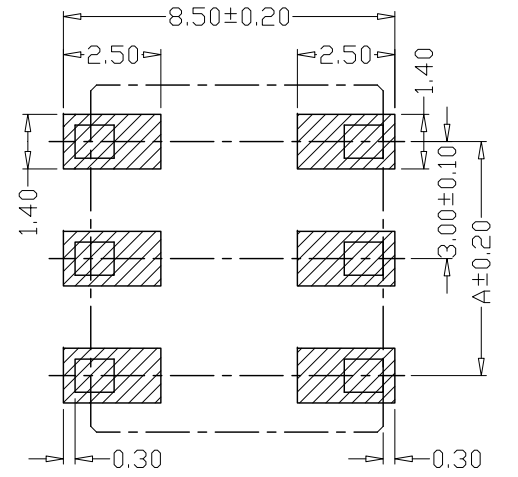

PCB LAYOUT

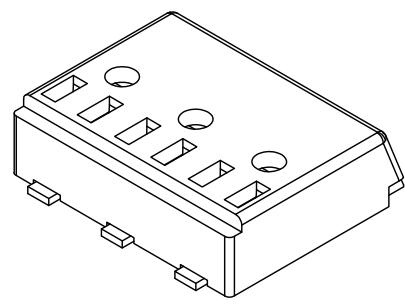
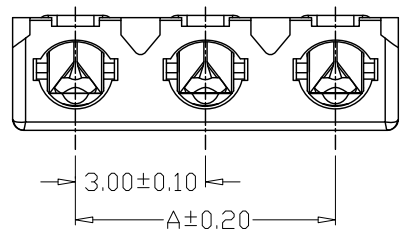
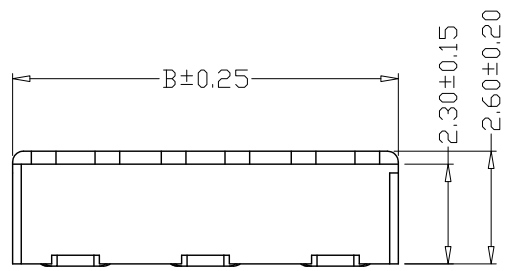
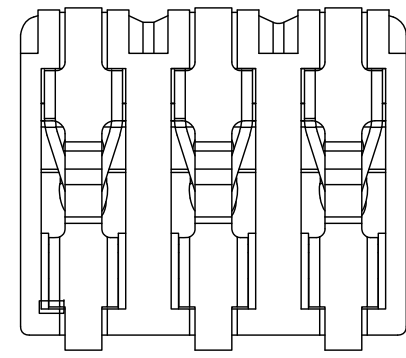
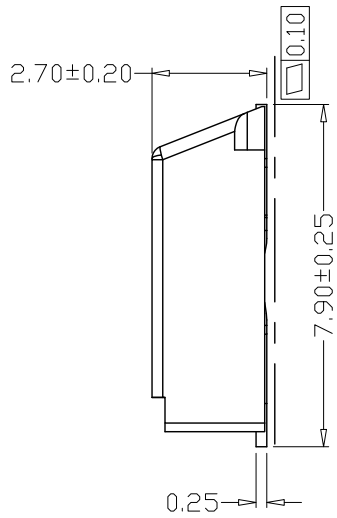
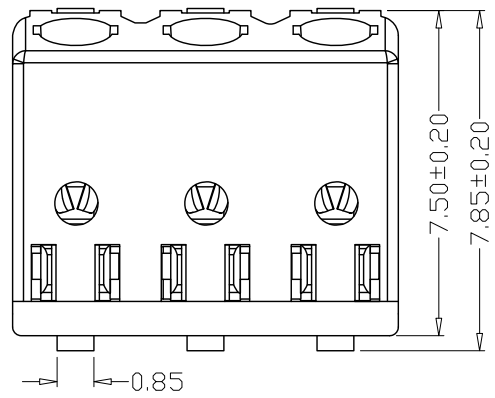

SPECIFICATIONS

- 1、Current Rating: 3A AC, DC
- 2、Voltage Rating: 160V AC, DC
- 3、Temperatuer Range: -40℃~+130℃
- 4、Contact Resistance: 20mΩ Max
- 5、Insulation Resistance: 1000MΩ Min
- 6、Withstanding Voltang: 1300V AC/minute
- 7、Material: Wafer LCP, UL94V-0
PIN Phosphoric bronzes Tin-plated

PIN	尺寸 (mm)	
	A	B
2059-01AWB	--	3.00
2059-02AWB	3.00	6.00
2059-03AWB	6.00	9.00

GENREL TOLERANCE		制图 Mapping	张迎春 2022、09、12	料号 PART NO.	B30003-nAWB	版本 REV.	A
X±0.25	X°±2°	审核 Audit	钱岳生 2022、09、12	品名 TITLE	2059卧贴 WAFER SMT TYPE	页次 SHEET	1/1
.XX±0.15	.XX°±0.5°	核准 Approved	张名 2022、09、13	客户料号 CUTM. NO.		乐清市宏一电子有限公司 YueQing HongYi Electronics Co., Ltd	
.XXX±0.10	.XXX°±0.5°	单位 Units	MM	比例 SCALE	1:1		